

No. 22BD-1859

ISSUED: OCT. 15, 1997

REVISED: OCT. 19, 2005



HOSHIZAKI SELF-CONTAINED ICE MAKER

**MODEL CM-90DE
 CM-110DE
 FM-120DE
 FM-120DE-N**

PARTS LIST (HE)

A-0	DEC.2000	F-1	JUL.1996
B-0	DEC.2001	G-1	JUL.1997
C-0	DEC.2002	H-1	DEC.1997
D-0	DEC.2003	H-2	FEB.1998
D-1	JAN.2004	H-3	MAR.1998
D-2	JAN.2004	H-4	MAY 1998
		J-1	DEC.1998
		K-0	DEC.1999

FINAL

MATERIAL ABBREVIATIONS

PLASTIC

ABS	=	Acrylonitrile-butadien-styrene
AC	=	Polyacetal
EVA	=	Ethylene vinyl acetate
PA	=	Polyamide = Nylon
PC	=	Polycarbonate
PE	=	Polyethylene
PES	=	Polyester
PETP	=	Polyethylene terephthalate = Tetlon
PF	=	Phenol-formaldehyde
PP	=	Polypropyleneoride
PS	=	Polystyrene
PTFE	=	Polytetrafluoroethylene = Teflon
PUR	=	Polyurethane
PVC	=	Polyvinyl chloride

RUBBER

EPDM	=	EP rubber
NBR	=	Nitrile butadiene rubber
NR	=	Natural rubber
SI.R	=	Silicone rubber
SY.R	=	Synthetic rubber

STEEL

G.S	=	Galvanized steel
S.S	=	Stainless steel

AUXILIARY CODE

Ex.1

K-0
└─┬─┘ Parts are the same as in the preceding year.
└──┘ "K" is the tenth in alphabetical order with "I" skipped.
So, "K" indicates "1990".

Ex.2

A-1
└─┬─┘ "A" is the first in alphabetical order.
└──┘ So, "A" indicates "1991".

Ex.3

A-2
└─┬─┘ Each time a part is changed in a year, this number advances.

(Note)

— = Part deleted.
X = Part deleted and replaced by "O" part.
O = New part for "X" in the same auxiliary code.

FASTENER ABBREVIATION LIST

ST	Phillips Truss Head Machine Screw
SP	Phillips Pan Head Machine Screw
SF	Phillips Flat Head Machine Screw
SS	Phillips Pan Head Machine Screw with Split Lock Washer
SW	Phillips Pan Head Machine Screw with Split Lock Washer and Flat Washer
T1	Phillips Truss Head Tapping Screw (Correspond to Type A)
T2	Phillips Truss Head Tapping Screw (Correspond to Type B)
T3	Phillips Truss Head Tapping Screw (Correspond to Type C)
FT	Phillips Truss Head Tapping Screw (Special)
BH	Hexagon Head Bolt
BC	Socket Head Cap Screw
BS	Hexagon Bolt with Split Washer
BW	Hexagon Bolt with Split Washer and Flat Washer
BF	Hexagon Flange Bolt
BR	Cross-Recessed Hexagon Head Bolt
BRW	Cross-Recessed Hexagon Head Bolt with Split Lock Washer and Flat Washer
WL	Split Lock Washer
WT	External Tooth Washer
WF	Flat Washer
WS	Spring Washer
NH	Hexagon Nut
NF	Hexagon Flange Nut
NC	Hexagon Cap Nut
NS	Square Nut
NW	Wing Nut

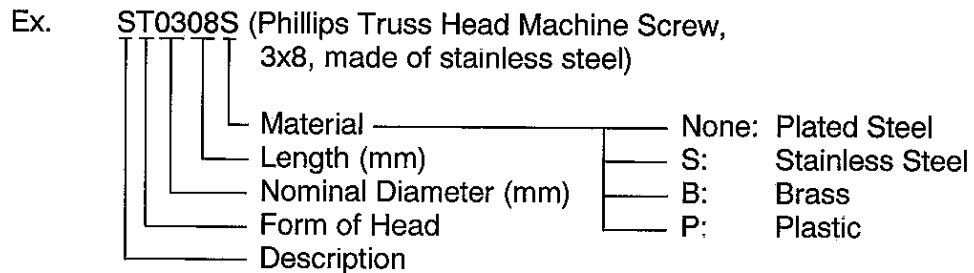

(Note) Second character is numerical except the list.

Ex. S1, S2, B3 etc.

And abbreviations and names are shown under the illustration.

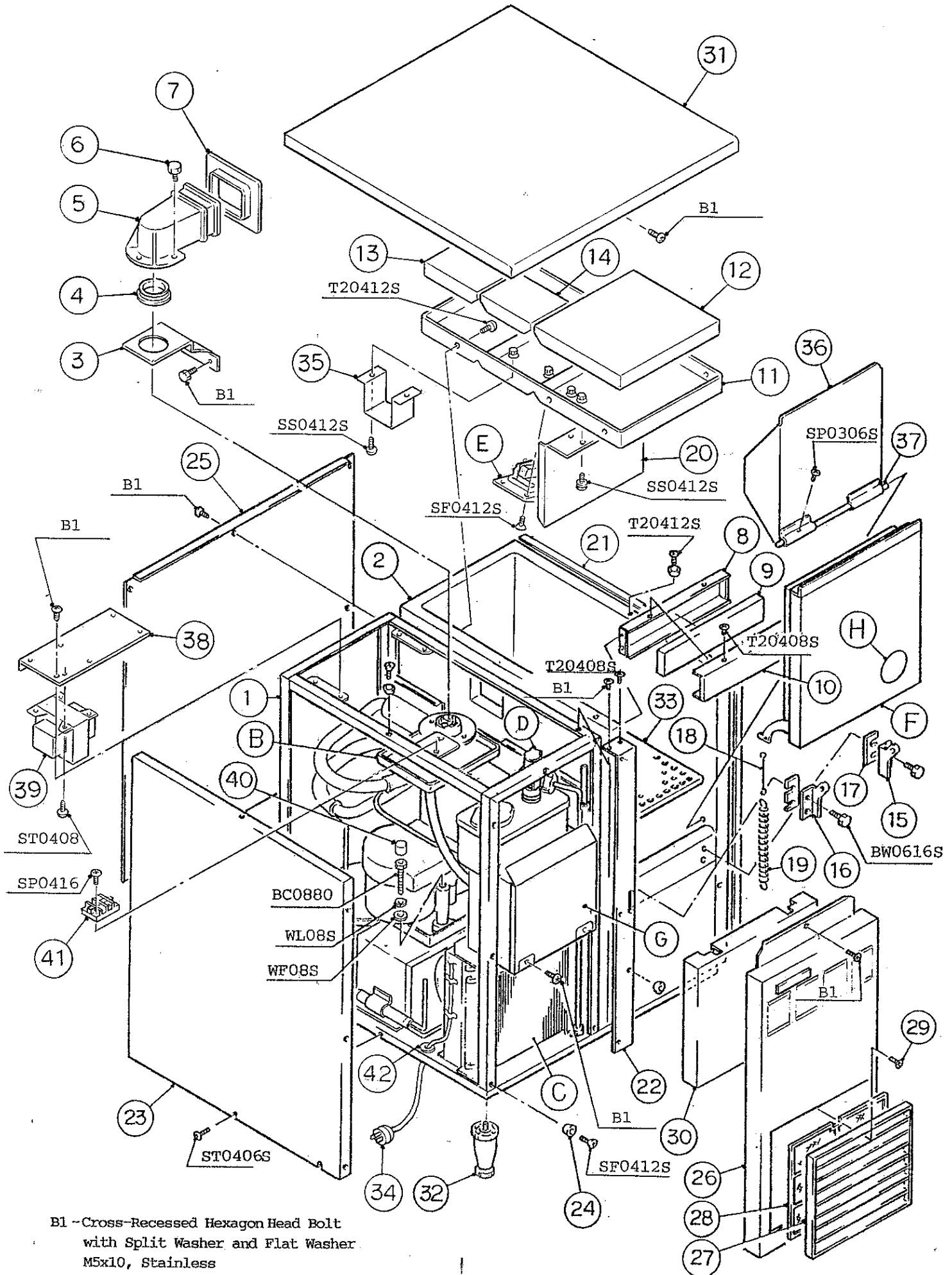

B1 - Cross-Recessed Hexagon Head Bolt
with Split Washer and Flat Washer
M5x10, Stainless

HE

CM-110DE
FM-120DE, FM-120DE-N

A. GENERAL ASSY

(K-0)(J-1)(H-4)-(D-2)
(H-3)(H-2)(H-1)

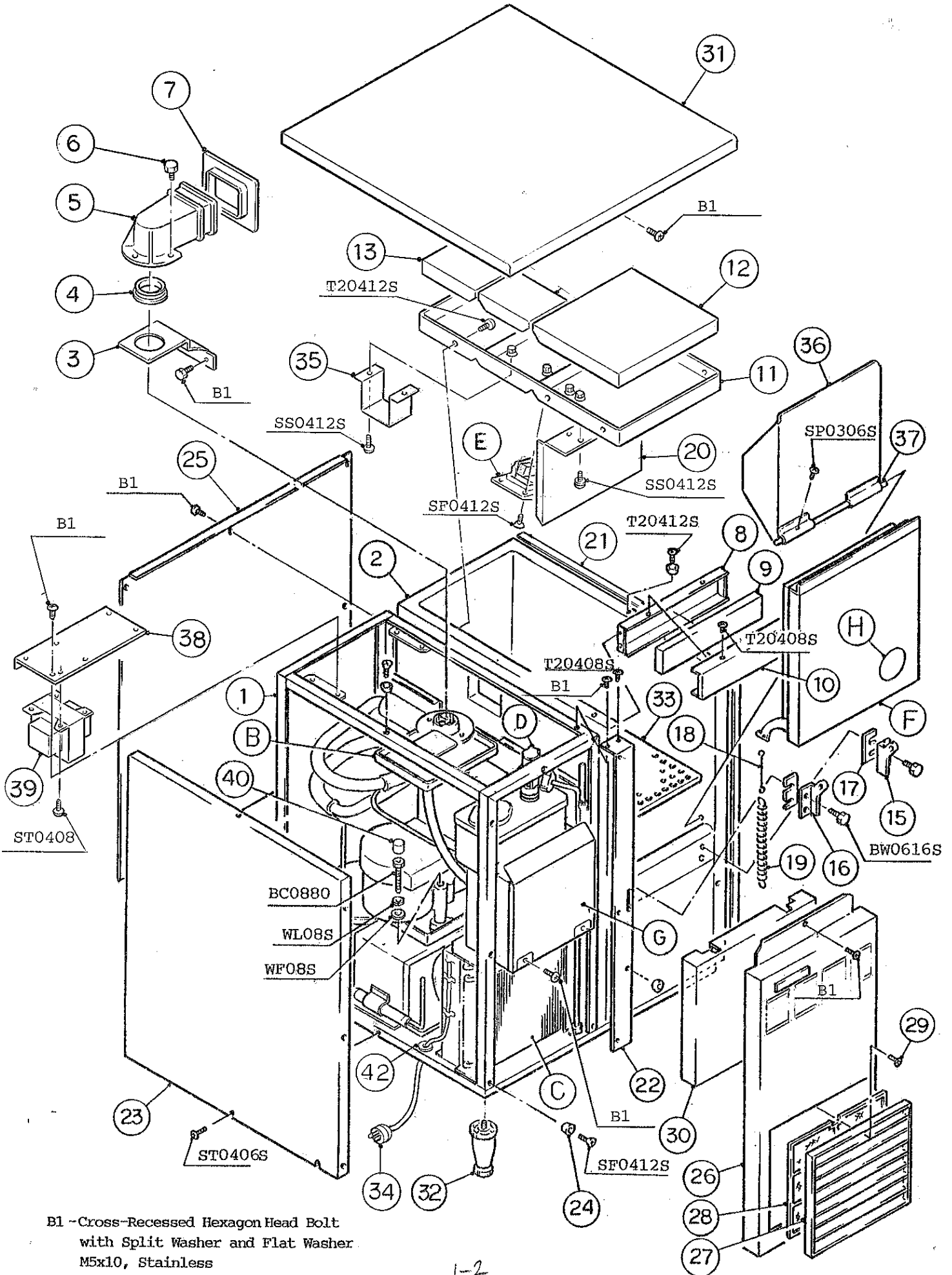

B1 - Cross-Recessed Hexagon Head Bolt
with Split Washer and Flat Washer.
M5x10, Stainless

HE

MODEL: CM-90DE, CM-110DE TITLE: A. GENERAL ASSY							
FM-120DE, FM-120DE-N							
INDEX NO.	DESCRIPTION	MATERIAL OR MODEL NUMBER	PART NUMBER	REQ'D NUMBER			
				F-1	G-1	H-1 H-2 H-3	H-4 J-1 K-0 A-0
B	ICE MAKING UNIT	-	-	1	1	1	1
C	REFRIGERATION CIRCUIT	-	-	1	1	1	1
D	WATER CIRCUIT ASSY	-	-	1	1	1	1
E	BIN SWITCH ASSY	(S-0360)	310810A01	1	1	1	1
F	DOOR ASSY	-	310998A06	1	1	1	1
G	CONTROL BOX ASSY	-	336726A01	1	1	1	-
		-	341579A01				1
H	LABEL LOCATION	(CM-90DE)	224391A01	1	1	-	
	LABEL LOCATION	(CM-110DE)	228228A01			1	1
	LABEL LOCATION	(FM-120DE)	224391A02	1	1	-	
			228228A02			1	1
LABEL LOCATION	(FM-120DE-N)	228228A04				1	
1	FRAME	STEEL	108065G01	1	1	1	1
2	BIN - FOAMED	ABS	205776G07	1	1	1	1
3	BRACKET - EVAPORATOR	S.S	318532-01	1	1	1	1
4	PACKING - CYLINDER	EPDM	427151-01	1	1	1	1
5	SPOUT	PC	208791-01	1	1	1	1
6	THUMBSCREW	S.S, ABS	415949G03	3	3	3	3
7	PACKING (C) - SPOUT	EPDM	430837-01	1	1	1	1
8	FRAME - FRONT	S.S	430921-01	1	1	1	1
9	INSULATION - FRONT COVER	PS FOAM	418332-01	1	1	1	1
10	FRONT FRAME	S.S	418333-01	1	1	1	1
11	COVER - BIN TOP	(CM-90, 110DE) ABS	224390G01	1	1	1	1
	COVER - BIN TOP	(FM-120DE, -N) ABS	224338G01	1	1	1	1
12	INSULATION	(CM-90, 110DE) PE FOAM	418711-01	1	1	1	1
	INSULATION (A)	(FM-120DE, -N) PE FOAM	418334-01	1	1	1	1
13	INSULATION (B)	PE FOAM	418334-02	1	1	1	1

HE

MODEL: CM-90DE, CM-110DE		TITLE: A. GENERAL ASSY					
		FM-120DE, FM-120DE-N					
INDEX NO.	DESCRIPTION	MATERIAL OR MODEL NUMBER	PART NUMBER	REQ'D NUMBER			
				B-0	C-0	D-0	D-1
B	ICE MAKING UNIT	-	-	1			
C	REFRIGERATION CIRCUIT	-	-	1			
D	WATER CIRCUIT ASSY	-	-	1			
E	BIN SWITCH ASSY	(S-0360)	310810A01	1			
F	DOOR ASSY	-	310998A06	1			
G	CONTROL BOX ASSY	-	341579A01	1			
H	LABEL LOCATION	(CM-110DE)	228228A01	1			
	LABEL LOCATION	(FM-120DE)	228228A02	1			
	LABEL LOCATION	(FM-120DE-N)	228228A04	1			
1	FRAME	STEEL	108065G01	1			
2	BIN - FOAMED	ABS	205776G07	1			
3	BRACKET - EVAPORATOR	S.S	318532-01	1			
4	PACKING - CYLINDER	EPDM	427151-01	1			
5	SPOUT	PC	208791-01	1			
6	THUMBSCREW	S.S, ABS	415949G03	3			
7	PACKING (C) - SPOUT	EPDM	430837-01	1			
8	FRAME - FRONT	S.S	430921-01	1			
9	INSULATION - FRONT COVER	PS FOAM	418332-01	1			
10	FRONT FRAME	S.S	418333-01	1			
11	COVER - BIN TOP	(CM-90, 110DE) ABS	224390G01	1			
	COVER - BIN TOP	(FM-120DE, -N) ABS	224338G01	1			
12	INSULATION	(CM-90, 110DE) PE FOAM	418711-01	1			
	INSULATION (A)	(FM-120DE, -N) PE FOAM	418334-01	1			
13	INSULATION (B)	PE FOAM	418334-02	1			

HE

MODEL: CM-90DE, CM-110DE FM-120DE, FM-120DE-N				TITLE: A. GENERAL ASSY			
INDEX NO.	DESCRIPTION	MATERIAL OR MODEL NUMBER	PART NUMBER	REQ'D NUMBER			
				F-1	G-1	H-1 H-2 H-3	H-4 J-1 K-0 A-0
14	INSULATION (E)	PE FOAM	418335-04	1	1	1	1
15	HINGE (RIGHT)	S.S	4H0456-01	1	1	1	1
16	HINGE (LEFT)	S.S	426053-01	1	1	1	1
17	HINGE SPACER (B)	S.S	4H0605-02	2	2	2	2
18	HOOK (H)	S.S	404060-07	1	1	1	1
19	SPRING	ZINC COATED PIANO WIRE	4H0491-01	1	1	1	1
20	SEPARATOR - STORAGE BIN	(CM-90, 110DE) S.S	418710-01	1	1	1	1
21	SIDE PANEL (RIGHT)	S.S	311006-03	1	1	1	1
22	CENTER PANEL	S.S	312081-01	1	1	1	1
23	SIDE PANEL (LEFT)	S.S	336140-02	1	1	1	1
24	COLLAR	S.S	4H0171-01	6	6	6	6
25	REAR PANEL	S.S	336141-02	1	1	1	1
26	FRONT PANEL (LEFT)	S.S	217479-03	1	1	1	1
27	LOUVER (A)	CALP	103344-07	1	1	1	1
28	AIR FILTER (A)	PP	208840G03	1	1	1	1
29	TAPPING SCREW (BLACK)	STEEL, 4x8	433954-01	1	1	1	1
30	FRONT PANEL (RIGHT)	S.S	311011-01	1	1	1	1
31	TOP PANEL	S.S	322860G05	1	1	1	1
32	ADJUSTABLE LEG	SDNH-100HN- 12EP	429119-01	4	4	4	4
33	DRAIN BOARD	S.S	418336-01	1	1	1	1
34	POWER SUPPLY CORD (CONTINENTAL)	GTCE-3	450412-01	1	1	1	1
	POWER SUPPLY CORD (UK)	GTBS-3	452359-01	1	1	1	1
35	BRACKET	S.S	450431-01	1	1	1	1
36	SLOPE	ABS	310996G01	1	1	1	1
37	SHAFT - DOOR, INNER BIN	S.S	418796-01	1	1	1	1

HE

MODEL: CM-90DE, CM-110DE FM-120DE, FM-120DE-N		TITLE: A. GENERAL ASSY					
INDEX NO.	DESCRIPTION	MATERIAL OR MODEL NUMBER	PART NUMBER	REQ'D NUMBER			
				B-0	C-0	D-0	D-1
14	INSULATION (E)	PE FOAM	418335-04	1			
15	HINGE (RIGHT)	S.S	4H0456-01	1			
16	HINGE (LEFT)	S.S	426053-01	1			
17	HINGE SPACER (B)	S.S	4H0605-02	2			
18	HOOK (H)	S.S	404060-07	1			
19	SPRING	ZINC COATED PIANO WIRE	4H0491-01	1			
20	SEPARATOR - STORAGE BIN	(CM-90, 110DE) S.S	418710-01	1			
21	SIDE PANEL (RIGHT)	S.S	311006-03	1			
22	CENTER PANEL	S.S	312081-01	1			
23	SIDE PANEL (LEFT)	S.S	336140-02	1			
24	COLLAR	S.S	4H0171-01	6			
25	REAR PANEL	S.S	336141-02	1			
26	FRONT PANEL (LEFT)	S.S	217479-03	1			
27	LOUVER (A)	CALP	103344-07	1			
28	AIR FILTER (A)	PP	208840G03	1			
29	TAPPING SCREW (BLACK)	STEEL, 4x8	433954-01	1			
30	FRONT PANEL (RIGHT)	S.S	311011-01	1			
31	TOP PANEL	S.S	322860G05	1			
32	ADJUSTABLE LEG	SDNH-100HN- 12EP	429119-01	4			
33	DRAIN BOARD	S.S	418336-01	1			
34	POWER SUPPLY CORD (CONTINENTAL)	GTCE-3	450412-01	1			
	POWER SUPPLY CORD (UK)	GTBS-3	452359-01	1			
35	BRACKET	S.S	450431-01	1			
36	SLOPE	ABS	310996G01	1			
37	SHAFT - DOOR, INNER BIN	S.S	418796-01	1			

HE

MODEL: CM-90DE, CM-110DE				TITLE: A. GENERAL ASSY			
FM-120DE, FM-120DE-N							
INDEX NO.	DESCRIPTION	MATERIAL OR MODEL NUMBER	PART NUMBER	REQ'D NUMBER			
				F-1	G-1	H-1 H-2 H-3	H-4 J-1 K-0 A-0
38	BRACKET - TRANSFORMER	G.S	336643-01	1	1	-	
		G.S	339878-01			1	1
39	TRANSFORMER	TR7777	451024-01	1	1	-	
		PK12-17708	434570-01			1	1
40	VINYL CAP	PVC	451272-01	3	3	3	3
41	TERMINAL BOARD	T-20C	406251-01	1	1	-	
42	BUSHING	CEE-SR6P10	448949-01	1	1	1	1

HE

MODEL: CM-90DE, CM-110DE				TITLE: A. GENERAL ASSY			
FM-120DE, FM-120DE-N							
INDEX NO.	DESCRIPTION	MATERIAL OR MODEL NUMBER	PART NUMBER	REQ'D NUMBER			
				B-0	C-0	D-0	D-1
38	BRACKET - TRANSFORMER	G.S	339878-01	1			
39	TRANSFORMER	PK12-17708	434570-01	1			
40	VINYL CAP	PVC	451272-01	3			
41							
42	BUSHING	CEE-SR6P10	448949-01	1			

HE
CM-90DE, CM-110DE
FM-120DE, FM-120DE-N

B. ICE MAKING UNIT

(K-0) (J-1)-(D-2)
(H-4) (H-3) (H-2)
(G-1) (H-1) (F-1)

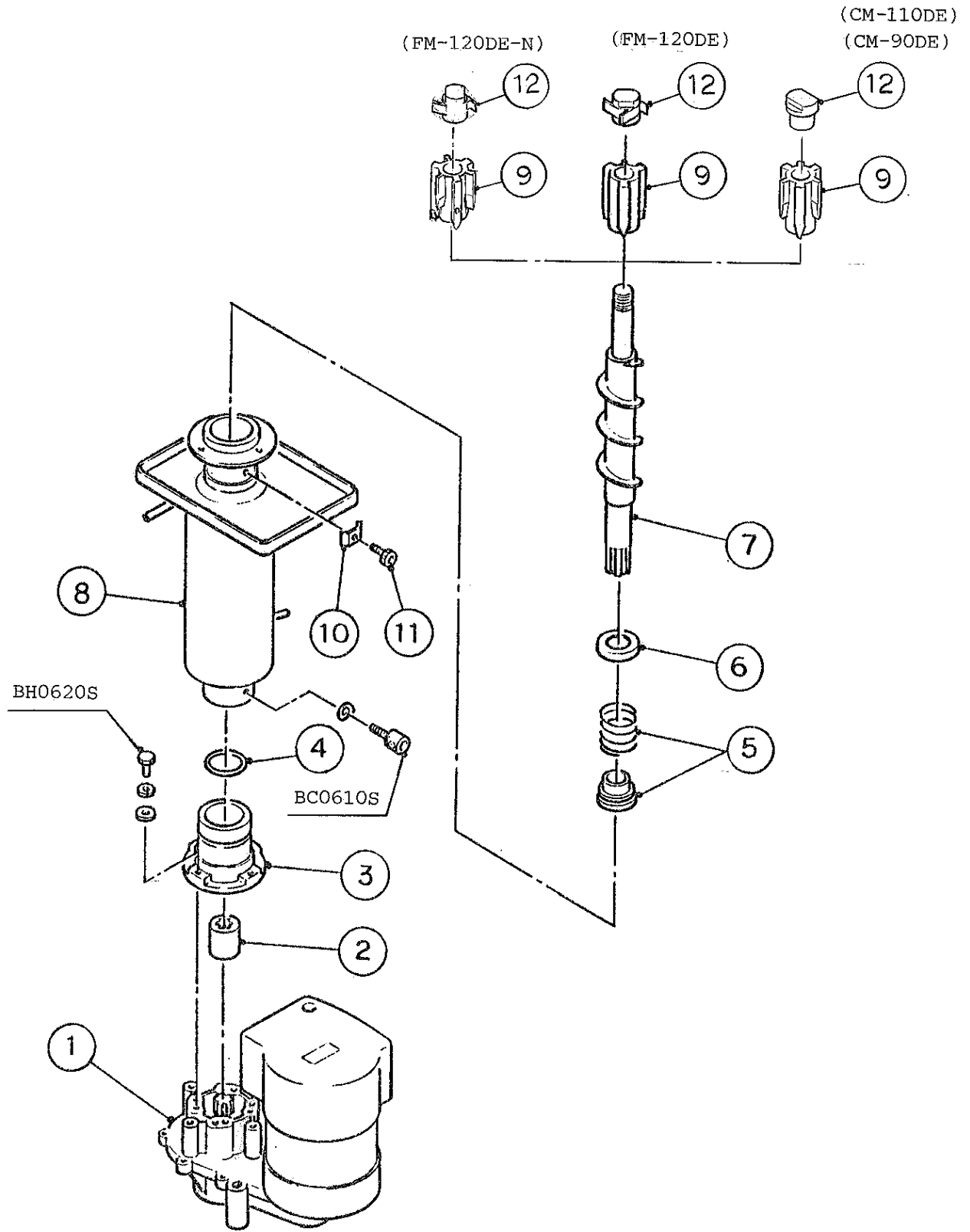

HE

MODEL: CM-90DE, CM-110DE TITLE: B. ICE MAKING UNIT							
FM-120DE, FM-120DE-N							
INDEX NO.	DESCRIPTION	MATERIAL OR MODEL NUMBER	PART NUMBER	REQ'D NUMBER			
				F-1	G-1	H-1 H-2 H-3	H-4 J-1 K-0 A-0
1	GEAR MOTOR	TC1149	450455-01	1	1	1	1
2	COUPLING - SPLINE	S.S	418316-01	1	1	1	1
3	HOUSING	COPPER ALLOY	206013G03	1	1	1	1
4	"O" RING	G40	7616-G040	1	1	1	1
5	MECHANICAL SEAL	HK9A-MS	432491-01	1	1	1	1
6	RING (B)	S.S	432494-01	1	1	1	1
7	AUGER	S.S	328527G01	1	1	1	1
8	EVAPORATOR	-	318478G01	1	1	1	1
9	EXTRUDING HEAD / 45C	(CM-90, 110DE) S.S	327236G01	1	1	1	1
	EXTRUDING HEAD / 45F	(FM-120DE), S.S	327140G01	1	1	1	1
	EXTRUDING HEAD / 45N	(FM-120DE-N) S.S	327141G01				1
10	WASHER	S.S	427138-01	3	3	3	3
11	SOCKET HEAD CAP SCREW	S.S, M8x14	429121-01	3	3	3	3
12	CUTTER	(CM-90, 110DE) S.S	439228G01	1	1	1	1
	CUTTER	(FM-120DE), S.S	427137-01	1	1	1	1
	CUTTER	(FM-120DE-N) S.S	440905-01				1

HE

MODEL: CM-90DE, CM-110DE TITLE: B. ICE MAKING UNIT							
FM-120DE, FM-120DE-N							
INDEX NO.	DESCRIPTION	MATERIAL OR MODEL NUMBER	PART NUMBER	REQ'D NUMBER			
				B-0	C-0	D-0	D-1
1	GEAR MOTOR	TC1149	450455-01	1			
2	COUPLING - SPLINE	S.S	418316-01	1			
3	HOUSING	COPPER ALLOY	206013G03	1			
4	"O" RING	G40	7616-G040	1			
5	MECHANICAL SEAL	HK9A-MS	432491-01	1			
6	RING (B)	S.S	432494-01	1			
7	AUGER	S.S	328527G01	1			
8	EVAPORATOR	-	318478G01	1			
9	EXTRUDING HEAD / 45C	(CM-90, 110DE) S.S	327236G01	1			
	EXTRUDING HEAD / 45F	(FM-120DE), S.S	327140G01	1			
	EXTRUDING HEAD / 45N	(FM-120DE-N) S.S	327141G01	1			
10	WASHER	S.S	427138-01	3			
11	SOCKET HEAD CAP SCREW	S.S, M8x14	429121-01	3			
12	CUTTER	(CM-90, 110DE) S.S	439228G01	1			
	CUTTER	(FM-120DE), S.S	427137-01	1			
	CUTTER	(FM-120DE-N) S.S	440905-01	1			

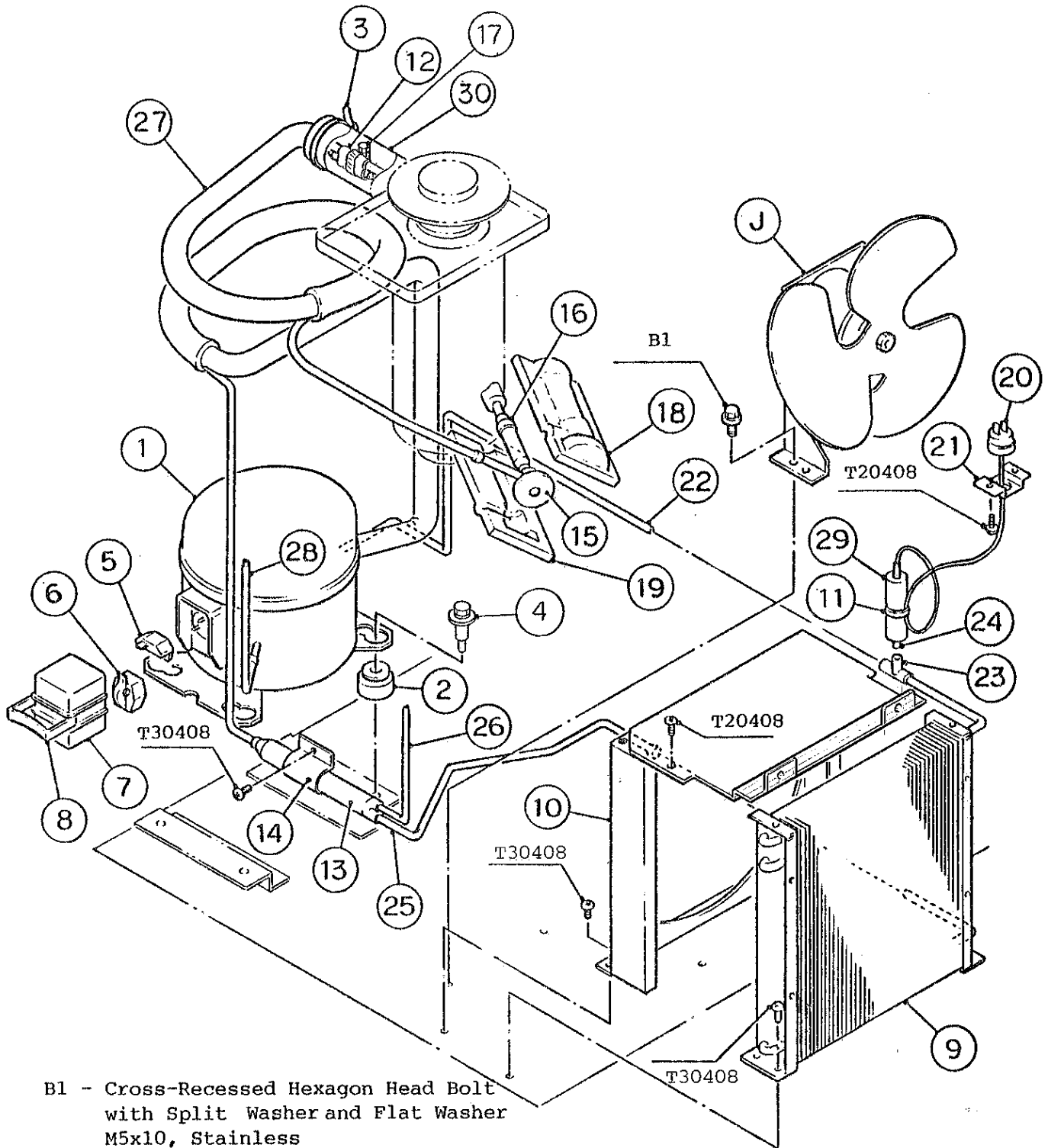

B1 - Cross-Recessed Hexagon Head Bolt with Split Washer and Flat Washer M5x10, Stainless

HE
CM-110DE

FM-120DE, FM-120DE-N

C. REFRIGERATION CIRCUIT

(K-0)(J-1)(H-4)-(D-2)
(H-3)(H-2)(H-1)

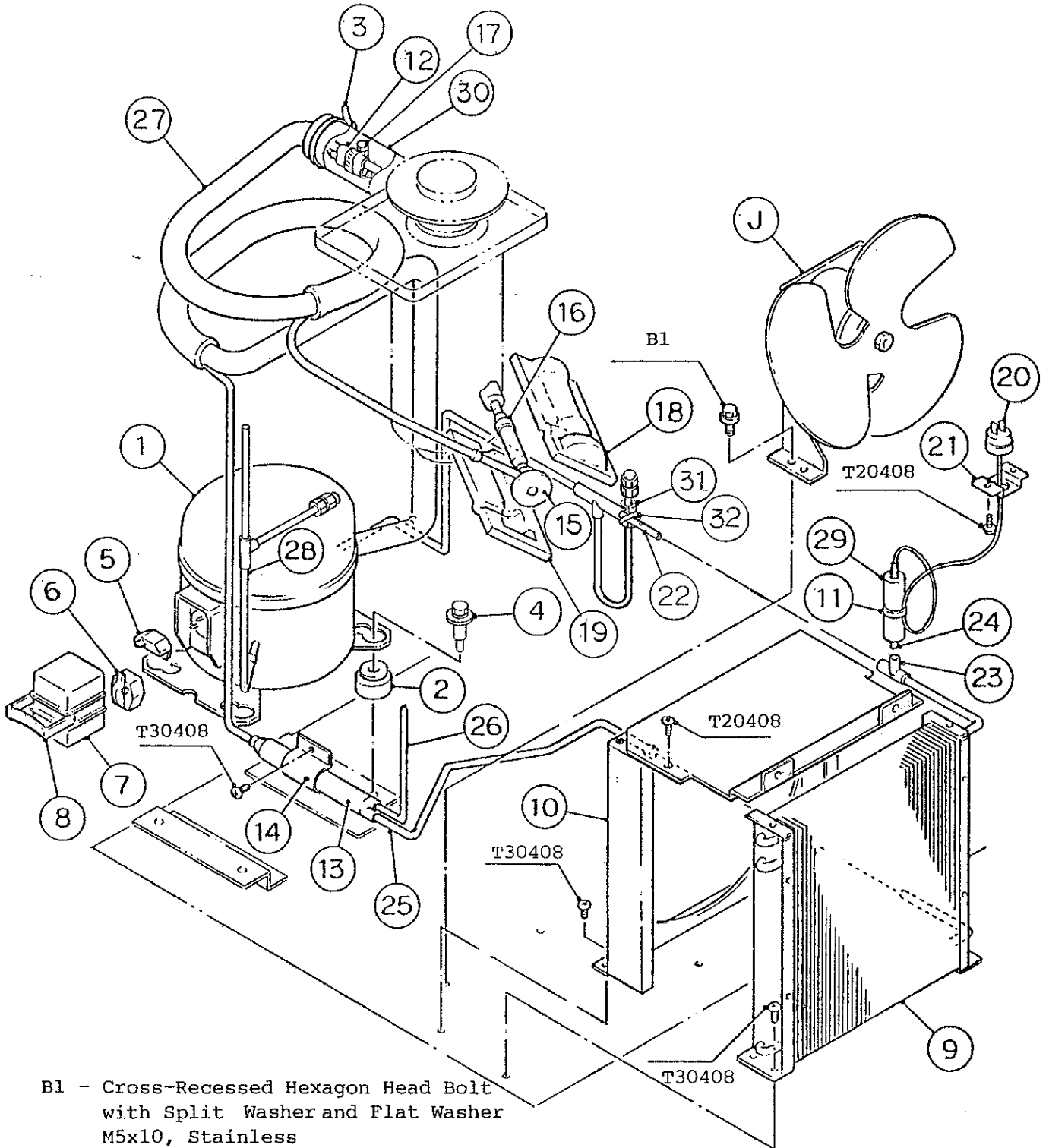

B1 - Cross-Recessed Hexagon Head Bolt
with Split Washer and Flat Washer
M5x10, Stainless

HE

MODEL: CM-90DE, CM-110DE TITLE: C. REFRIGERATION CIRCUIT							
FM-120DE, FM-120DE-N							
INDEX NO.	DESCRIPTION	MATERIAL OR MODEL NUMBER	PART NUMBER	REQ'D NUMBER			
				F-1	G-1	H-1 H-2 H-3	H-4 J-1 K-0 A-0
J	FAN MOTOR ASSY	(S-0911)	336283A01	1	1	1	1
1	COMPRESSOR	KE100Y-5ZV	444737-01	1	1	1	1
2	CUSHION	CR-Y2	443695-01	4	4	4	4
3	TIE	CV-150	7920-0003	4	4	4	4
4	BOLT	-	448834-01	4	4	4	4
5	OVERLOAD	4TM408UFBYY-62	448090-01	1	1	1	1
6	CONNECTOR	-	435923-01	1	1	1	1
7	TERMINAL COVER		434797-01	1	1	1	1
8	STRAP	S.S	434798-01	1	1	1	1
9	CONDENSER - AIR-COOLED	-	210453-03	1	1	1	1
10	SHROUD	G.S	224314G01	1	1	1	1
11	TIE	CV-100	7920-0002	1	1	1	1
12	HOLDER - EXP. VALVE - 3/8	S.S	3A0107-01	1	1	1	-
	HOLDER - EXP. VALVE		451267-01				1
13	DRIER	KC-7860	444395-01	1	1	1	1
14	STRAP	G.S	419349-01	1	1	1	1
15	EXPANSION VALVE	HFE-5QHD-1	446808-01	1	1	1	1
16	REDUCER	COPPER	421904-01	1	1	1	1
17	CLAMP	S.S	443461-02	1	1	1	1
18	COVER (C) - EXPANSION VALVE	PE FOAM	324313-03	1	1	1	1
19	COVER (D) - EXPANSION VALVE	PE FOAM	324313-04	1	1	1	1
20	PRESSURE SWITCH	ACB-2UB05	433441-06	1	1	1	1
21	BRACKET - PRESSURE SWITCH	G.S	425506-01	1	1	1	1
22	COPPER TUBE (H1)	COPPER	329589-02	1	1	-	
	COPPER TUBE A/H	COPPER	340763G01			1	1
23	TEE	COPPER	420041-03	1	1	1	1
24	COPPER TUBE (A) - CAPILLARY	COPPER	446047-01	1	1	1	1
25	COPPER TUBE (H2)	COPPER	442787-01	1	1	1	1
26	PROCESS TUBE (B)	COPPER	428058-02	1	1	1	1
27	HEAT EXCHANGER	COPPER	218669G01	1	1	1	1

HE

MODEL: CM-90DE, CM-110DE TITLE: C. REFRIGERATION CIRCUIT							
FM-120DE, FM-120DE-N							
INDEX NO.	DESCRIPTION	MATERIAL OR MODEL NUMBER	PART NUMBER	REQ'D NUMBER			
				B-0	C-0	D-0	D-1
J	FAN MOTOR ASSY	(S-0911)	336283A01	1			
1	COMPRESSOR	KE100Y-5ZV	444737-01	1			
2	CUSHION	CR-Y2	443695-01	4			
3	TIE	CV-150	7920-0003	4			
4	BOLT	-	448834-01	4			
5	OVERLOAD	4TM408UFBYY-62	448090-01	1			
6	CONNECTOR	-	435923-01	1			
7	TERMINAL COVER		434797-01	1			
8	STRAP	S.S	434798-01	1			
9	CONDENSER - AIR-COOLED	-	210453-03	1			
10	SHROUD	G.S	224314G01	1			
11	TIE	CV-100	7920-0002	1			
12	HOLDER - EXP. VALVE		451267-01	1			
13	DRIER	KC-7860	444395-01	-			
		DY-15QHD-1	458772-01	1			
14	STRAP	G.S	419349-01	1			
15	EXPANSION VALVE	HFE-5QHD-1	446808-01	1			
16	REDUCER	COPPER	421904-01	1			
17	CLAMP	S.S	443461-02	1			
18	COVER (C) - EXPANSION VALVE	PE FOAM	324313-03	1			
19	COVER (D) - EXPANSION VALVE	PE FOAM	324313-04	1			
20	PRESSURE SWITCH	ACB-2UB05	433441-06	1			
21	BRACKET - PRESSURE SWITCH	G.S	425506-01	1			
22	COPPER TUBE A/H	COPPER	340763G01	1			
23	TEE	COPPER	420041-03	1			
24	COPPER TUBE (A) - CAPILLARY	COPPER	446047-01	1			
25	COPPER TUBE (H2)	COPPER	442787-01	1			
26	PROCESS TUBE (B)	COPPER	428058-02	1			
27	HEAT EXCHANGER	COPPER	218669G01	1			

HE

MODEL: CM-90DE, CM-110DE		TITLE: C. REFRIGERATION CIRCUIT					
		FM-120DE, FM-120DE-N					
INDEX NO.	DESCRIPTION	MATERIAL OR MODEL NUMBER	PART NUMBER	REQ'D NUMBER			
				F-1	G-1	H-1 H-2 H-3	H-4 J-1 K-0 A-0
28	PROCESS TUBE	COPPER	442853-01	1	1	-	
	COPPER TUBE B/L	COPPER	454274G01			1	1
29	INSULATION TUBE	7762-0717, L=80	107335-38	1	1	1	1
30	INSULATION TUBE	7762-2949, L=140	107335-39	1	1	1	1
31	INSULATION TUBE	L=30	7762-0717			2	2
32	TIE	CV-100	7920-0002			2	2

HE

MODEL: CM-90DE, CM-110DE TITLE: C. REFRIGERATION CIRCUIT							
FM-120DE, FM-120DE-N							
INDEX NO.	DESCRIPTION	MATERIAL OR MODEL NUMBER	PART NUMBER	REQ'D NUMBER			
				B-0	C-0	D-0	D-1
28	COPPER TUBE B/L	COPPER	454274G01	1			
29	INSULATION TUBE	7762-0717, L=80	107335-38	1			
30	INSULATION TUBE	7762-2949, L=140	107335-39	1			
31	INSULATION TUBE	L=30	7762-0717	2			
32	TIE	CV-100	7920-0002	2			

HE
CM-90DE , CM-110DE
FM-120DE , FM-120DE-N

D. WATER CIRCUIT

(K-0) (J-1) - (D-2)
(H-4) (H-3) (H-2)
(G-1) (H-1) (F-1)

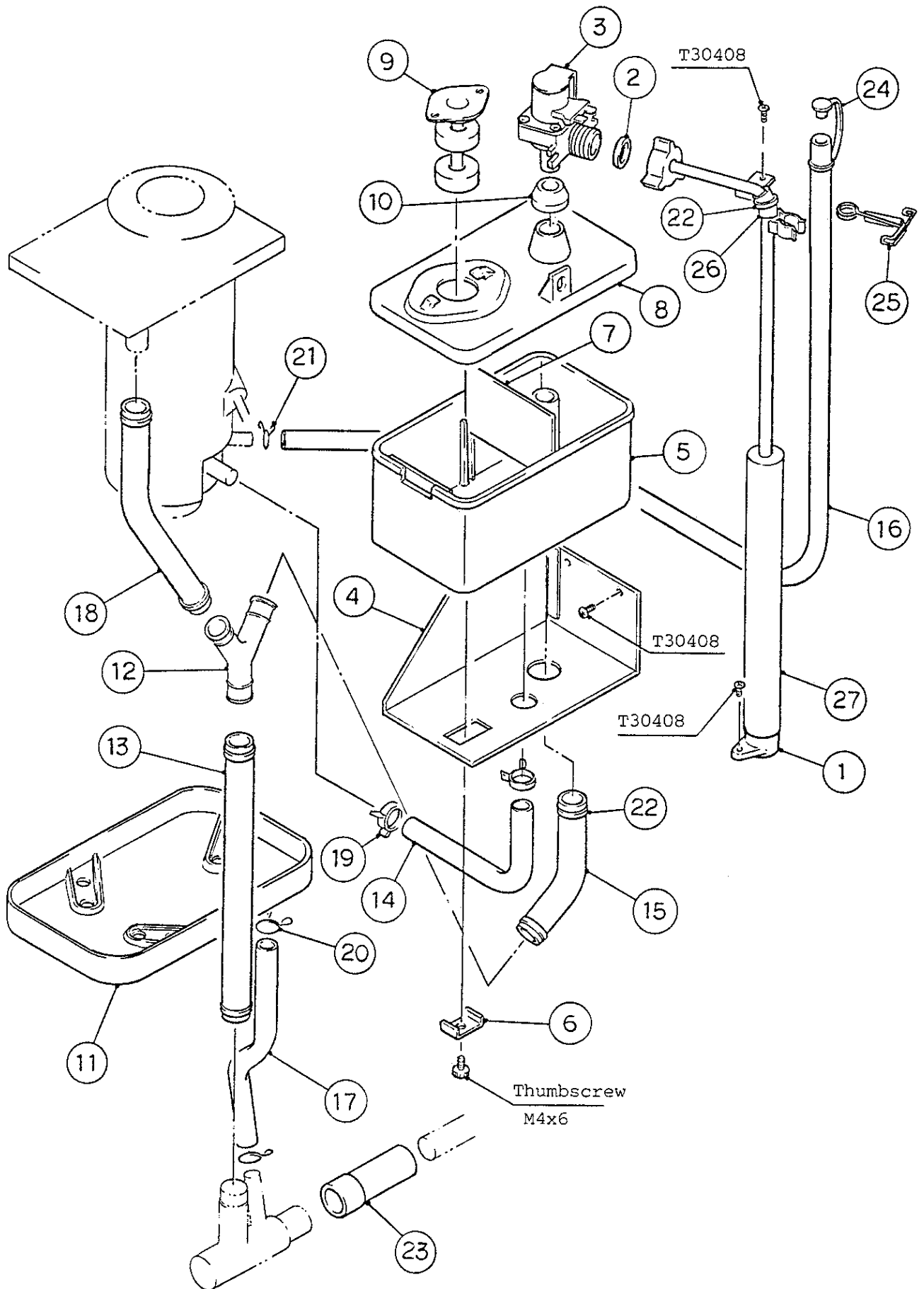

HE

MODEL: CM-90DE, CM-110DE TITLE: D. WATER CIRCUIT FM-120DE, FM-120DE-N							
INDEX NO.	DESCRIPTION	MATERIAL OR MODEL NUMBER	PART NUMBER	REQ'D NUMBER			
				F-1	G-1	H-1 H-2 H-3	H-4 J-1 K-0 A-0
1	PIPE - WATER SUPPLY	S.S	328517G01	1	1	1	-
		S.S	342401G01				1
2	PACKING	SI. R	413854-02	1	1	1	1
3	WATER VALVE	V-19	452358-01	1	1	1	-
			455733-01				1
4	BRACKET - RESERVOIR	G.S	328518-01	1	1	1	1
5	RESERVOIR	ABS	214802G01	1	1	1	1
6	COLLAR	S.S	423416-01	1	1	1	1
7	SEPARATOR - RESERVOIR	ABS	423538-01	1	1	1	1
8	COVER - RESERVOIR	ABS	103070-01	1	1	1	1
9	FLOAT SWITCH	TW-1221-101	435490-01	1	1	1	1
10	COVER - RESERVOIR INLET	SI. R	415094-01	1	1	1	1
11	DRAIN PAN	ABS	318155-01	1	1	1	1
12	"Y" JOINT	ABS	431347-01	1	1	1	1
13	HOSE	7716-1821, L=235	105668-16	1	1	1	1
14	SILICONE HOSE	7730-1216, L=180	105668-33	1	1	1	1
15	SILICONE HOSE	7730-1721, L=130	105668-34	1	1	1	1
16	HOSE	7716-0913, L=500	105668-19	1	1	1	1
17	HOSE	7716-1216, L=155	105668-20	1	1	1	1
18	HOSE	7711-1821, L=245	105668-21	1	1	1	1
19	CLAMP (D)	T15	423866-04	2	2	2	2
20	CLAMP	SK-16	435934-04	2	2	2	2
21	CLAMP	SK-13	435934-01	1	1	1	1
22	TIE	CV-150	7920-0003	7	7	7	7
23	HOSE - PUMP DISCHARGE	EPDM	415699-03	1	1	1	1

HE

MODEL: CM-90DE, CM-110DE		TITLE: D. WATER CIRCUIT					
		FM-120DE, FM-120DE-N					
INDEX NO.	DESCRIPTION	MATERIAL OR MODEL NUMBER	PART NUMBER	REQ'D NUMBER			
				B-0	C-0	D-0	D-1
1	PIPE - WATER SUPPLY	S.S	342401G01	1			
2	PACKING	SI. R	413854-02	1			
3	WATER VALVE		455733-01	1			
4	BRACKET - RESERVOIR	G.S	328518-01	1			
5	RESERVOIR	ABS	214802G01	1			
6	COLLAR	S.S	423416-01	1			
7	SEPARATOR - RESERVOIR	ABS	423538-01	1			
8	COVER - RESERVOIR	ABS	103070-01	1			
9	FLOAT SWITCH	TW-1221-101	435490-01	1			
10	COVER - RESERVOIR INLET	SI. R	415094-01	1			
11	DRAIN PAN	ABS	318155-01	1			
12	"Y" JOINT	ABS	431347-01	1			
13	HOSE	7716-1821, L=235	105668-16	1			
14	SILICONE HOSE	7730-1216, L=180	105668-33	1			
15	SILICONE HOSE	7730-1721, L=130	105668-34	1			
16	HOSE	7716-0913, L=500	105668-19	1			
17	HOSE	7716-1216, L=155	105668-20	1			
18	HOSE	7711-1821, L=245	105668-21	1			
19	CLAMP (D)	T15	423866-04	2			
20	CLAMP	SK-16	435934-04	2			
21	CLAMP	SK-13	435934-01	1			
22	TIE	CV-150	7920-0003	7			
23	HOSE - PUMP DISCHARGE	EPDM	415699-03	1			

HE

MODEL: CM-90DE, CM-110DE TITLE: D. WATER CIRCUIT
FM-120DE, FM-120DE-N

INDEX NO.	DESCRIPTION	MATERIAL OR MODEL NUMBER	PART NUMBER	REQ'D NUMBER			
				B-0	C-0	D-0	D-1
24	CAP	PE	414914-01	1			
25	PINCH - VALVE	5-192-02	439927-01	1			
26	HOSE	7716-0913, L=20	105668-29	1			
27	INSULATION TUBE	7762-1030, L=270	105668-30	1			

HE
CM-90DE, CM-110DE
FM-120DE, FM-120DE-N

E. BIN SWITCH ASSY

(K-0) (J-1)-(D-2)
(H-4) (H-3) (H-2)
(G-1) (H-1) (F-1)

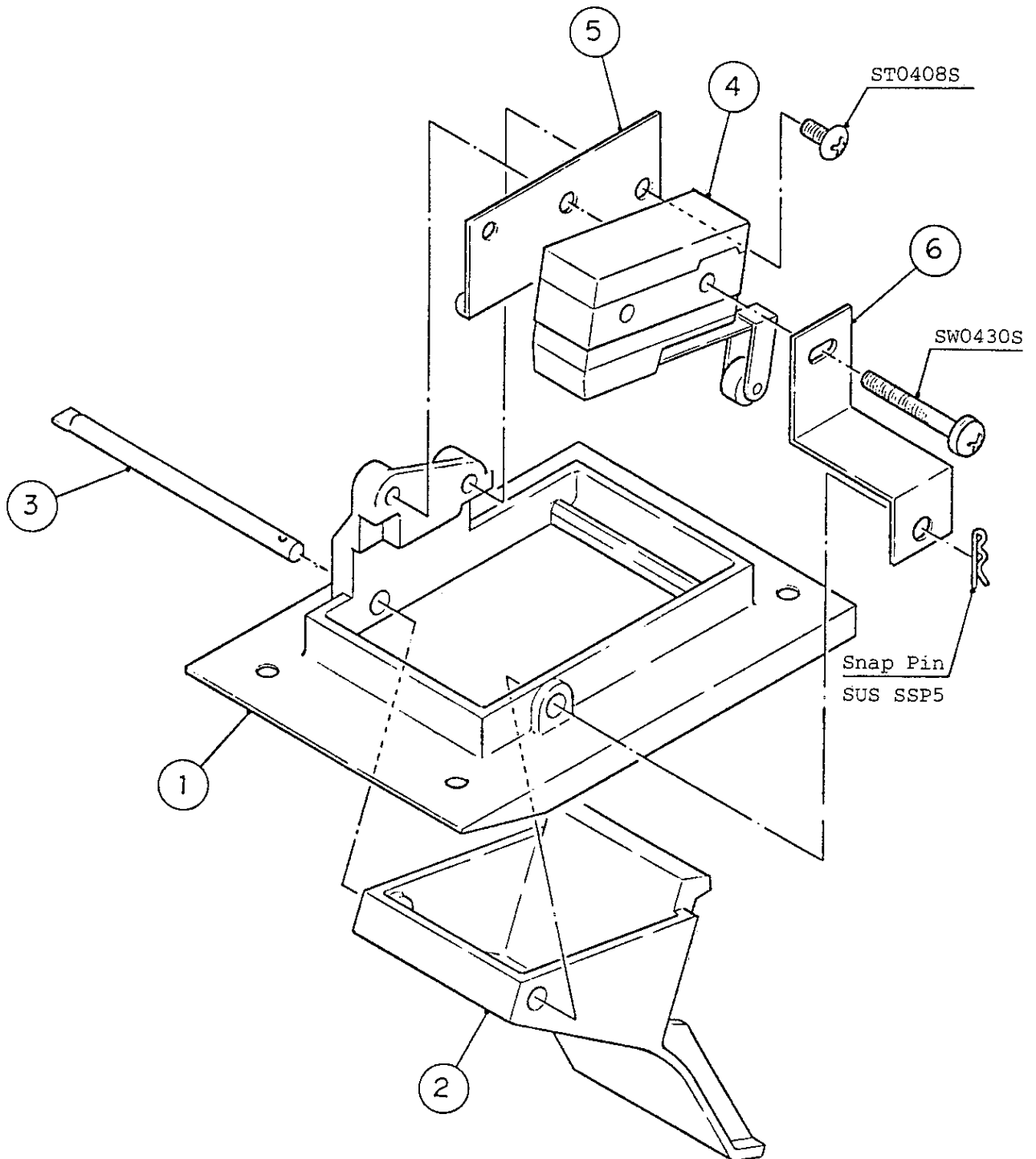

HE

MODEL: CM-90DE, CM-110DE TITLE: E. BIN SWITCH ASSY							
FM-120DE, FM-120DE-N							
INDEX NO.	DESCRIPTION	MATERIAL OR MODEL NUMBER	PART NUMBER	REQ'D NUMBER			
				F-1	G-1	H-1 H-2 H-3	H-4 J-1 K-0 A-0
1	BASE - BIN CONTROL	AC	310808-01	1	1	1	1
2	PLATE - BIN CONTROL	AC	310809-01	1	1	1	1
3	SHAFT	AC	417979-01	1	1	1	1
4	MICROSWITCH	Z-15GW38355- MLE	421582-01	1	1	1	1
5	BRACKET - SWITCH	S.S	428013-01	1	1	1	1
6	BRACKET	S.S	441961-01	1	1	1	1

HE

MODEL: CM-90DE, CM-110DE TITLE: E. BIN SWITCH ASSY							
FM-120DE, FM-120DE-N							
INDEX NO.	DESCRIPTION	MATERIAL OR MODEL NUMBER	PART NUMBER	REQ'D NUMBER			
				B-0	C-0	D-0	D-1
1	BASE - BIN CONTROL	AC	310808-01	1			
2	PLATE - BIN CONTROL	AC	310809-01	1			
3	SHAFT	AC	417979-01	1			
4	MICROSWITCH	Z-15GW38355- MLE	421582-01	1			
5	BRACKET - SWITCH	S.S	428013-01	1			
6	BRACKET	S.S	441961-01	1			

HE
CM-90DE , CM-110DE
FM-120DE, FM-120DE-N

F. DOOR ASSY

(K-0)(J-1)-(D-2)
(H-4)(H-3)(H-2)
(G-1)(H-1)(F-1)

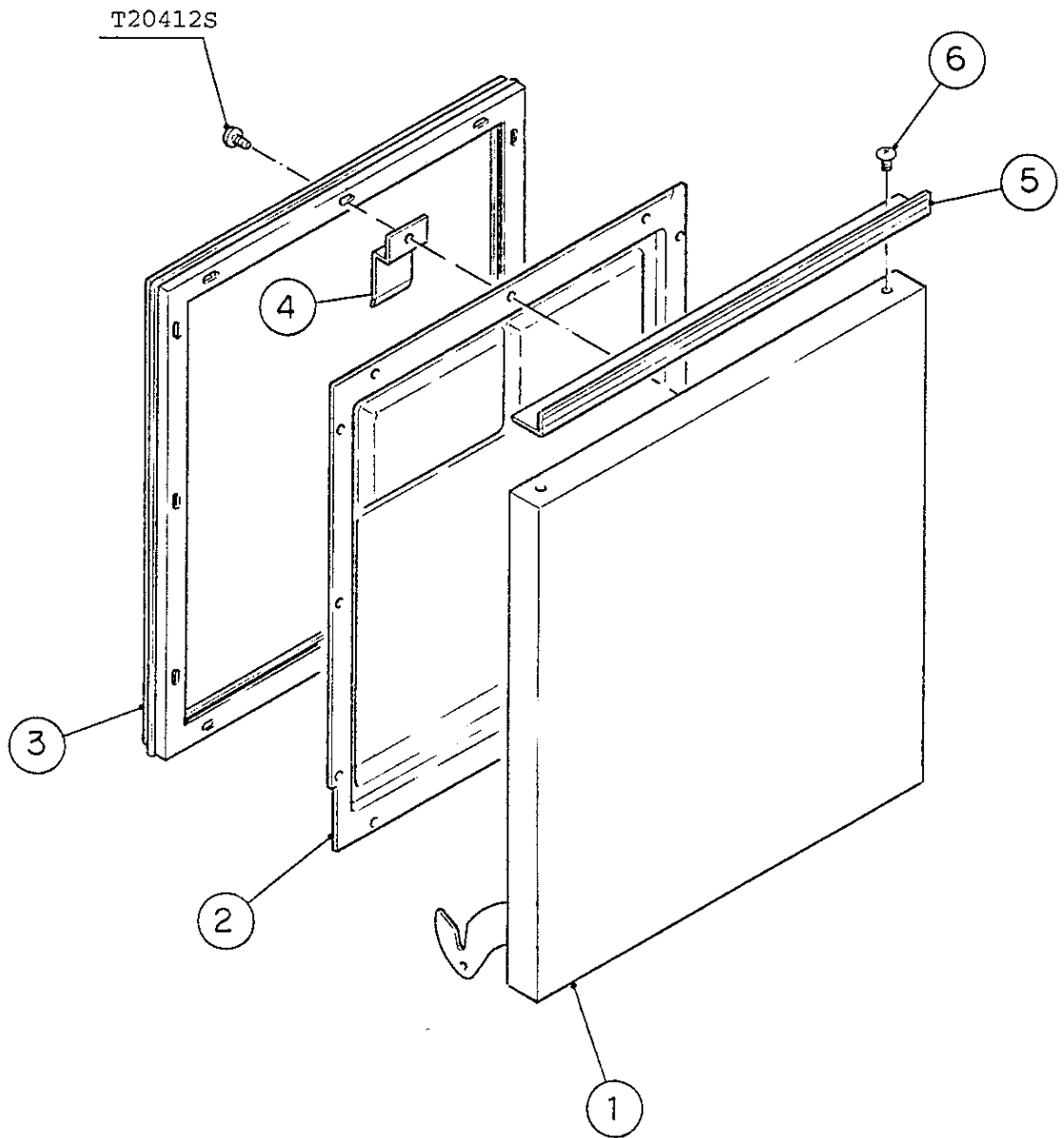

HE

MODEL: CM-90DE, CM-110DE FM-120DE, FM-120DE-N TITLE: F. DOOR ASSY							
INDEX NO.	DESCRIPTION	MATERIAL OR MODEL NUMBER	PART NUMBER	REQ'D NUMBER			
				F-1	G-1	H-1 H-2 H-3	H-4 J-1 K-0 A-0
1	DOOR	S.S	310999G01	1	1	1	1
2	PANEL - INNER DOOR	ABS	311002-01	1	1	1	1
3	GASKET	PVC	311003-01	1	1	1	1
4	CATCH	S.S	430661-01	1	1	1	1
5	HANDLE	ABS	310161-10	1	1	1	1
6	TAPPING SCREW - BLACK	STEEL, 4x12	433954-02	2	2	2	2

HE

MODEL: CM-90DE, CM-110DE TITLE: F. DOOR ASSY								
FM-120DE, FM-120DE-N								
INDEX NO.	DESCRIPTION	MATERIAL OR MODEL NUMBER	PART NUMBER	REQ'D NUMBER				
				B-0	C-0	D-0	D-1	D-2
1	DOOR	S.S	310999G01	1				
2	PANEL - INNER DOOR	ABS	311002-01	1				
3	GASKET	PVC	311003-01	1				
4	CATCH	S.S	430661-01	1				
5	HANDLE	ABS	310161-10	1				
6	TAPPING SCREW - BLACK	STEEL, 4x12	433954-02	2				

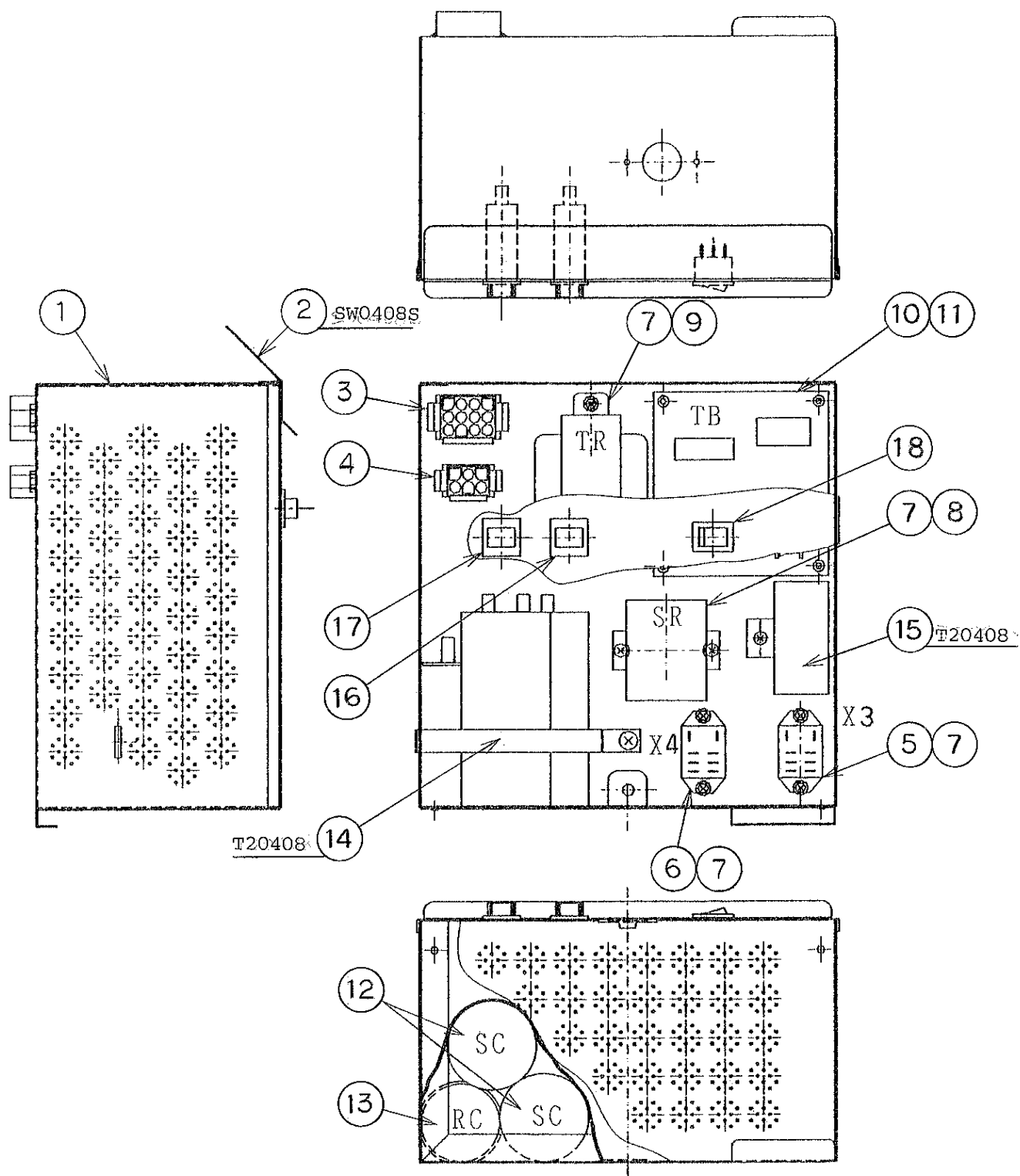

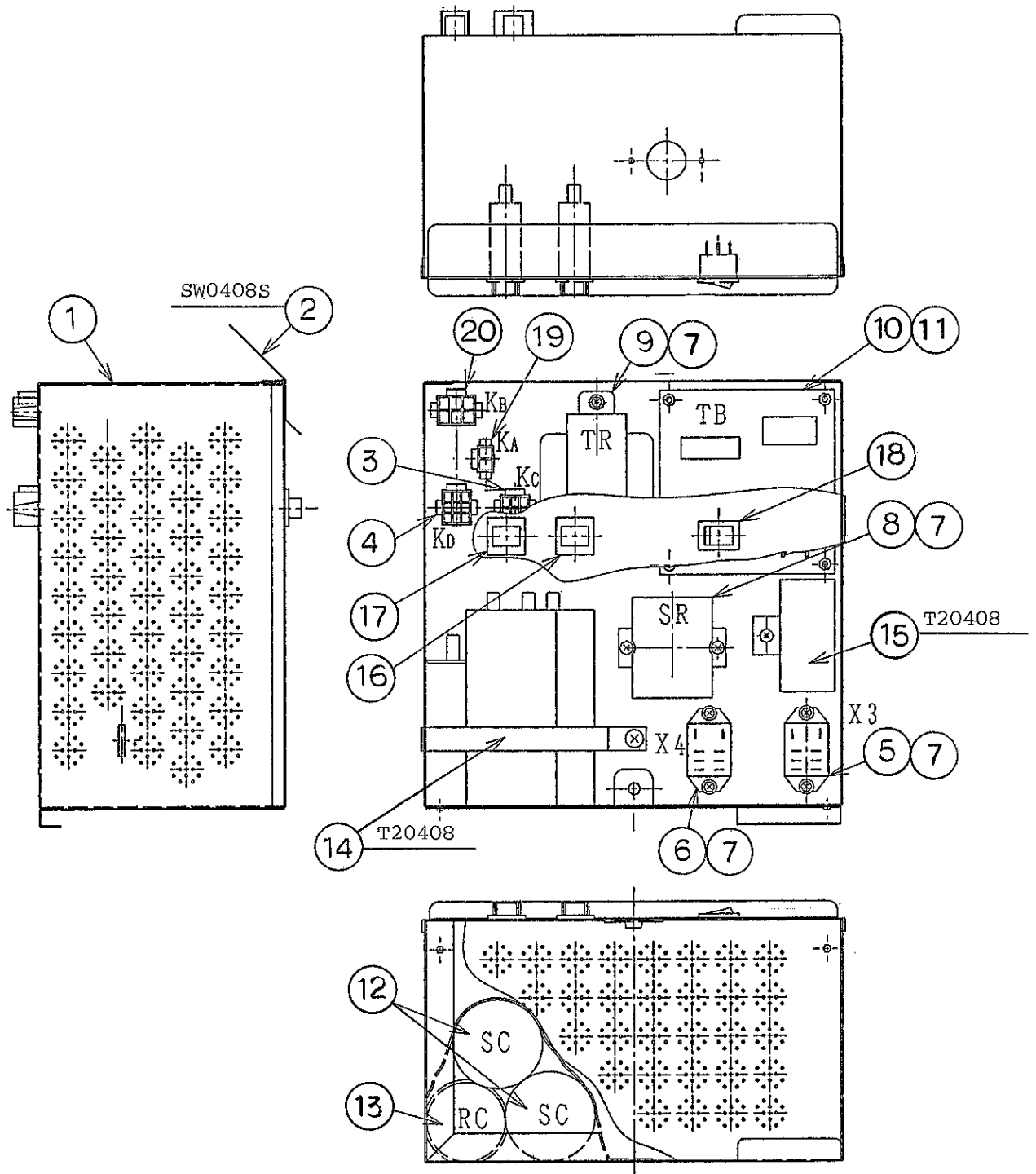

HE

MODEL: CM-90DE, CM-110DE TITLE: G. CONTROL BOX ASSY							
FM-120DE, FM-120DE-N							
INDEX NO.	DESCRIPTION	MATERIAL OR MODEL NUMBER	PART NUMBER	REQ'D NUMBER			
				F-1	G-1	H-1 H-2 H-3	H-4 J-1 K-0 A-0
1	CONTROL BOX	G.S	224343G01	1	1	1	-
		G.S	229046G01				1
2	COVER - CONTROL BOX	G.S	336725G01	1	1	1	1
3	12P PLUG HOUSING	3191-12P-201	412832-04	1	1	1	-
	RECEPTACLE HOUSING	YLR-06V	454246-04				1
4	6P PLUG HOUSING	3191-06P-201	412832-03	1	1	1	-
	RECEPTACLE HOUSING	YLR-09V	454246-06				1
5	RELAY	LY2ZF, AC24V	406132-06	1	1	1	1
6	RELAY	LY2F, 100V	406132-01	1	1	1	1
7	TAPPING SCREW	3x8, STEEL	431415-01	8	8	8	8
8	STARTER	AMVL-300TA	439611-01	1	1	1	1
9	TRANSFORMER	TR7990	450438-01	1	1	1	1
10	TIMER BOARD	H2AA144C02	437305-02	1	1	1	1
11	BOARD SUPPORT	KGLS-6S	414929-01	4	4	4	4
12	START CAPACITOR	220MS100-R	439613-01	2	2	2	2
13	RUN CAPACITOR	RS43B605ULAA CA	448088-01	1	1	1	1
14	STRAP - CAPACITOR	G.S	427254-16	1	1	1	1
15	CAPACITOR	CME25B146D	450456-01	1	1	1	1
16	PROTECTOR	W28XQ1A-3	440972-02	1	1	1	1
17	PROTECTOR	W28XQ1A-6	440972-03	1	1	1	1
18	ROCKER SWITCH	JW-S11RWW	436955-01	1	1	1	1
19	RECEPTACLE HOUSING	VLR-02V	454247-02				1
20	RECEPTACLE HOUSING	VLR-06V	454247-05				1

HE

MODEL: CM-90DE, CM-110DE TITLE: G. CONTROL BOX ASSY							
FM-120DE, FM-120DE-N							
INDEX NO.	DESCRIPTION	MATERIAL OR MODEL NUMBER	PART NUMBER	REQ'D NUMBER			
				B-0	C-0	D-0	D-1
1	CONTROL BOX	G.S	229046G01	1			
2	COVER - CONTROL BOX	G.S	336725G01	1			
3	RECEPTACLE HOUSING	YLR-06V	454246-04	1			
4	RECEPTACLE HOUSING	YLR-09V	454246-06	1			
5	RELAY	LY2ZF, AC24V	406132-06	1			
6	RELAY	LY2F, 100V	406132-01	1			
7	TAPPING SCREW	3x8, STEEL	431415-01	8			
8	STARTER	AMVL-300TA	439611-01	1			
9	TRANSFORMER	TR7990	450438-01	1			
10	TIMER BOARD	H2AA144C02	437305-02	1			
11	BOARD SUPPORT	KGLS-6S	414929-01	4			
12	START CAPACITOR	220MS100-R	439613-01	-			
		220VAC100M	4Y1371-01	2			
13	RUN CAPACITOR	RS43B605ULAA CA	448088-01	1			
14	STRAP - CAPACITOR	G.S	427254-16	1			
15	CAPACITOR	CME25B146D	450456-01	1			
16	PROTECTOR	W28XQ1A-3	440972-02	1			
17	PROTECTOR	W28XQ1A-6	440972-03	1			
18	ROCKER SWITCH	JW-S11RWW	436955-01	1			
19	RECEPTACLE HOUSING	VLR-02V	454247-02	1			
20	RECEPTACLE HOUSING	VLR-06V	454247-05	1			

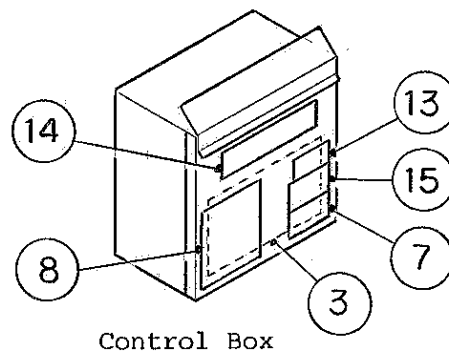
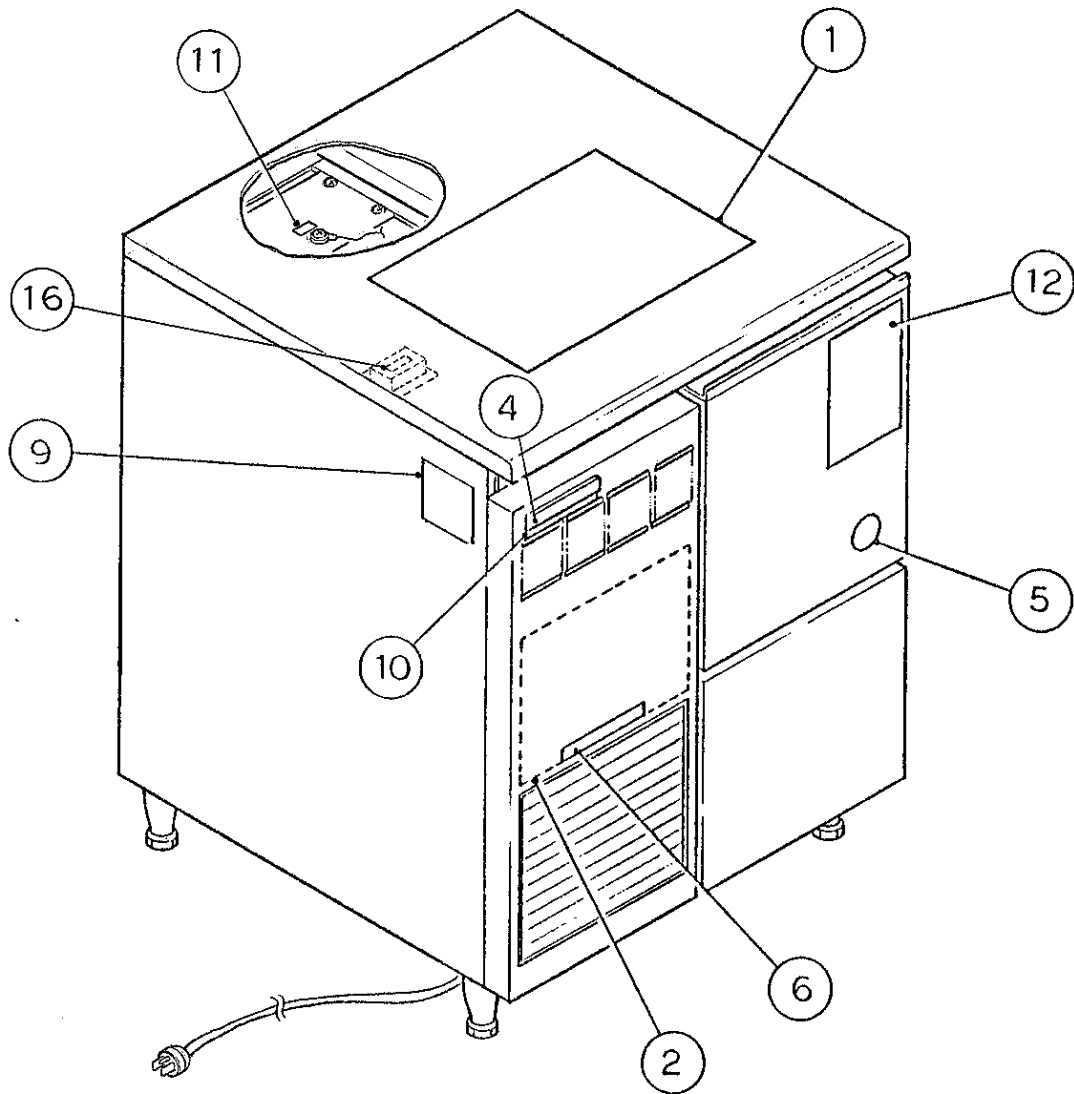

Control Box

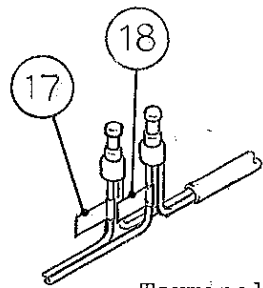
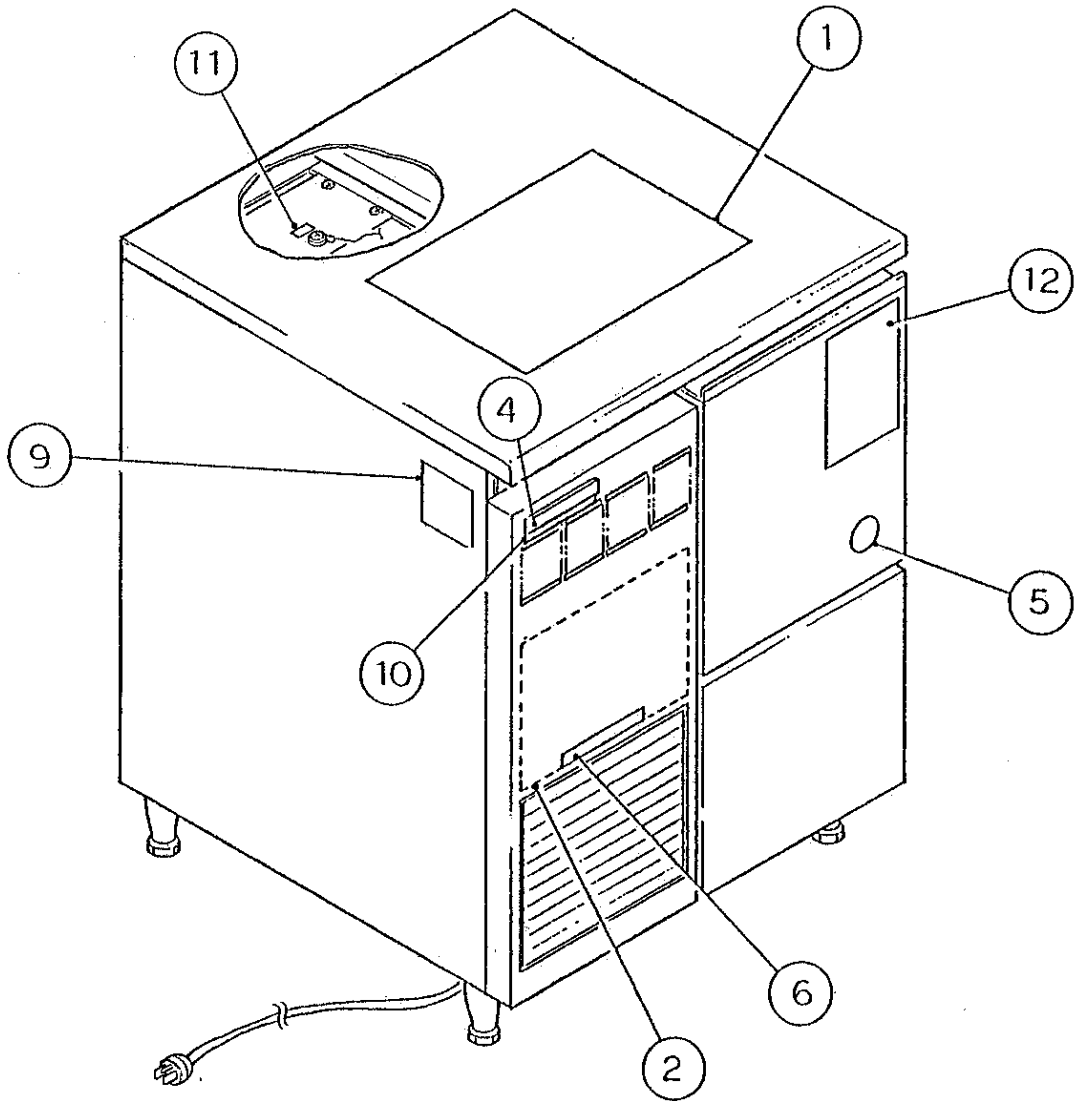

Terminal

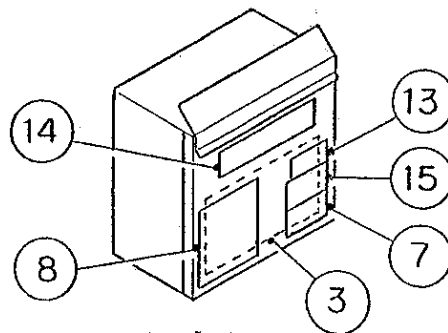

Control Box

HE

MODEL: CM-90DE, CM-110DE FM-120DE, FM-120DE-N				TITLE: H. LABEL LOCATION			
INDEX NO.	DESCRIPTION	MATERIAL OR MODEL NUMBER	PART NUMBER	REQ'D NUMBER			
				F-1	G-1	H-1 H-2 H-3	H-4 J-1 K-0 A-0
1	INSTRUCTION SHEET - INST. OPE.	PAPER	225738-01	1	1	1	1
2	MAINTENANCE LABEL	PVC FILM	225739-01	1	1	1	1
3	WIRING LABEL	PVC FILM	338013-01	1	1	-	
		PVC FILM	339851-01			1	1
4	EMBLEM (L) - HOSHIZAKI	ABS	418634G01	1	1	1	1
5	LABEL - PENGUIN	PETP FILM	434432-01	1	1	1	x1
		PETP FILM	454387-02				o1
6	LABEL - AIR FILTER	PETP FILM	426177-01	1	1	1	1
7	CAUTION LABEL (A)	PVC FILM	439141-01	1	1	1	1
8	LABEL - DRAIN	PVC FILM	439917-01	1	1	1	1
9	NAMEPLATE		N/A	1	1	1	1
10	MODEL NUMBER LABEL	(CM-90DE)	451849-**	1	1	-	
	MODEL NUMBER LABEL	(CM-110DE)	454275-**			1	1
	MODEL NUMBER LABEL	(FM-120DE)	451850-**	1	1	1	1
	MODEL NUMBER LABEL	(FM-120DE-N)	459435-**				1
11	LABEL - EARTH	PETP FILM	408598-01	1	1	1	-
		PETP FILM	450452-02				1
12	CAUTION LABEL	PETP FILM	332626-01	1	1	1	1
13	LABEL - R134a	PES FILM	444463-01	1	1	1	1
14	OPERATION LABEL	PVC FILM	450492-01	1	1	1	1
15	CAUTION LABEL (D)	PVC FILM	439144-01	1	1	1	1
16	LABEL - TERMINAL	PVC FILM	450489-01	1	1	-	
17	LABEL - TERMINAL		452379-03			1	1
18	LABEL - TERMINAL		452379-04			1	1

** is the same as the Auxiliary Code.

HE

MODEL: CM-90DE, CM-110DE		TITLE: H. LABEL LOCATION						
		FM-120DE, FM-120DE-N						
INDEX NO.	DESCRIPTION	MATERIAL OR MODEL NUMBER	PART NUMBER	REQ'D NUMBER				
				B-0	C-0	D-0	D-1	D-2
1	INSTRUCTION SHEET - INST. OPE.	PAPER	225738-01	1				
2	MAINTENANCE LABEL	PVC FILM	225739-01	1				
3	WIRING LABEL	PVC FILM	339851-01	1				
4	EMBLEM (L) - HOSHIZAKI	ABS	418634G01	-				
	EMBLEM		340842-01	1				
5	LABEL - PENGUIN	PETP FILM	454387-02	1				
6	LABEL - AIR FILTER	PETP FILM	426177-01	1				
7	CAUTION LABEL (A)	PVC FILM	439141-01	1				
8	LABEL - DRAIN	PVC FILM	439917-01	1				
9	NAMEPLATE		N/A	1				
10	MODEL NUMBER LABEL	(CM-110DE)	454275-**	1				
	MODEL NUMBER LABEL	(FM-120DE)	451850-**	1				
	MODEL NUMBER LABEL	(FM-120DE-N)	459435-**	1				
11	LABEL - EARTH	PETP FILM	450452-02	1				
12	CAUTION LABEL	PETP FILM	332626-01	1				
13	LABEL - R134a	PES FILM	444463-01	1				
14	OPERATION LABEL	PVC FILM	450492-01	1				
15	CAUTION LABEL (D)	PVC FILM	439144-01	1				
16								
17	LABEL - TERMINAL		452379-03	1				
18	LABEL - TERMINAL		452379-04	1				

** is the same as the Auxiliary Code.

(S-0911)

HE
CM-90DE, CM-110DE
FM-120DE, FM-120DE-N

J. FAN MOTOR ASSY

(K-0) (J-1) - (D-2)
(H-4) (H-3) (H-2)
(G-1) (H-1) (F-1)

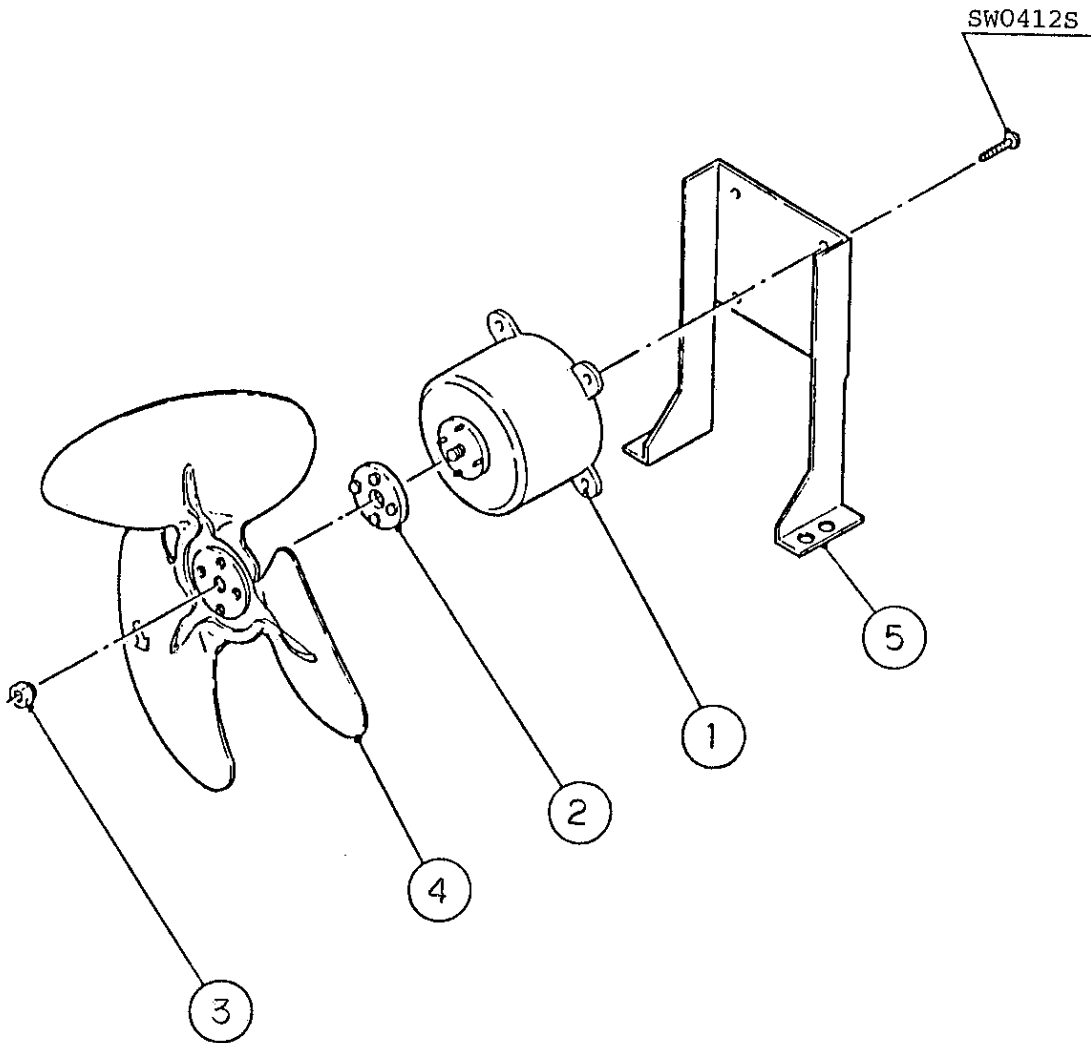

HE

MODEL: CM-90DE, CM-110DE		TITLE: J. FAN MOTOR ASSY					
		FM-120DE, FM-120DE-N					
INDEX NO.	DESCRIPTION	MATERIAL OR MODEL NUMBER	PART NUMBER	REQ'D NUMBER			
				F-1	G-1	H-1 H-2 H-3	H-4 J-1 K-0 A-0
1	FAN MOTOR	EKTZ64G, 8W	449986-01	1	1	1	1
2	VIBRATION PAD	SI. R	437776-01	1	1	1	1
3	NUT	STEEL	437777-01	1	1	1	1
4	FAN	230PB-2	437762-01	1	1	1	1
5	BRACKET - FAN MOTOR	G.S	336281-01	1	1	1	1

HE

MODEL: CM-90DE, CM-110DE TITLE: J. FAN MOTOR ASSY						
FM-120DE, FM-120DE-N						
INDEX NO.	DESCRIPTION	MATERIAL OR MODEL NUMBER	PART NUMBER	REQ'D NUMBER		
				B-0 C-0 D-0 D-1 D-2		
1	FAN MOTOR	EKTZ64G, 8W	449986-01	1		
2	VIBRATION PAD	SI. R	437776-01	1		
3	NUT	STEEL	437777-01	1		
4	FAN	230PB-2	437762-01	1		
5	BRACKET - FAN MOTOR	G.S	336281-01	1		

HE
CM-90DE, CM-110DE
FM-120DE, FM-120DE-N

K. ACCESSORIES

(K-0) (J-1) - (D-2)
(H-4) (H-3) (H-2)
(G-1) (H-1) (F-1)

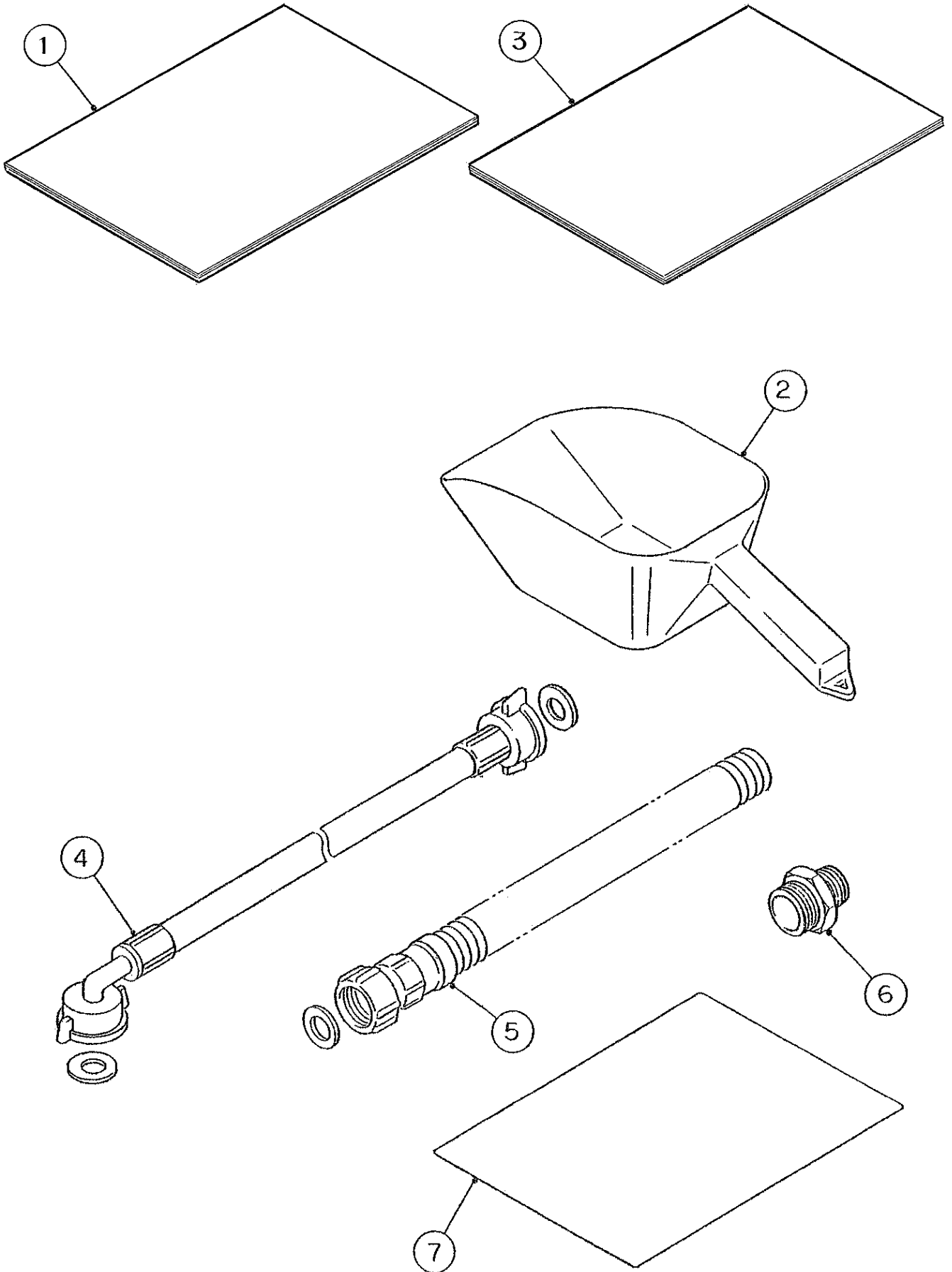

HE

MODEL: CM-90DE, CM-110DE FM-120DE, FM-120DE-N				TITLE: K. ACCESSORIES			
INDEX NO.	DESCRIPTION	MATERIAL OR MODEL NUMBER	PART NUMBER	REQ'D NUMBER			
				F-1	G-1	H-1 H-2 H-3	H-4 J-1 K-0 A-0
1	INSTRUCTION MANUAL	PAPER	9120BD15A	1	1	-	
		PAPER	9120BD20A			1	1
2	SCOOP	PE	208185-01	1	1	1	1
3	INSTALLATION MANUAL	PAPER	9220BD15A	1	1	-	
		PAPER	9220BD20A			1	1
4	INLET HOSE	HOSH01	450722-01	1	1	1	1
5	OUTLET HOSE	HOSH02	450723-01	1	1	1	1
6	ADAPTER / NIPPLE	BRASS	450724-01	1	1	1	1
7	INSTRUCTION SHEET	PAPER	225295-01	1	1	1	1

HE

MODEL: CM-90DE, CM-110DE					TITLE: K. ACCESSORIES			
FM-120DE, FM-120DE-N								
INDEX NO.	DESCRIPTION	MATERIAL OR MODEL NUMBER	PART NUMBER	REQ'D NUMBER				
				B-0	C-0	D-0	D-1	D-2
1	INSTRUCTION MANUAL	PAPER	9120BD20A	1				
2	SCOOP	PE	208185-01	1				
3	INSTALLATION MANUAL	PAPER	9220BD20A	1				
4	INLET HOSE	HOSH01	450722-01	1				
5	OUTLET HOSE	HOSH02	450723-01	1				
6	ADAPTER / NIPPLE	BRASS	450724-01	1				
7	INSTRUCTION SHEET	PAPER	225295-01	1				